

User Manual-Smart Cylinder

TTLOCK VERSION



Smart your life!

Version 1.0 Edition S1K

1 Packing Accessories

Please check the packing box and accessories when you got the item in hand.

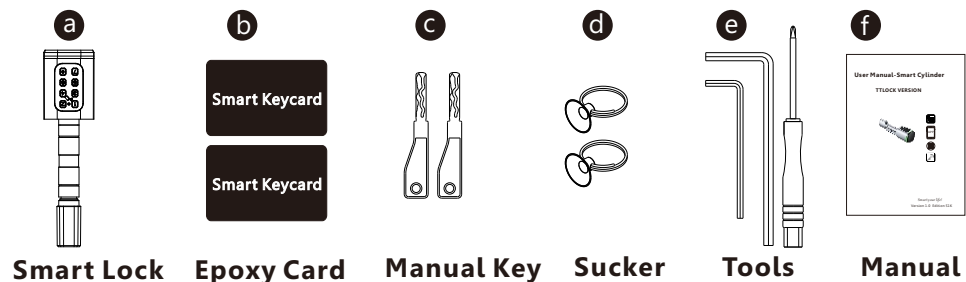

2 Product Specification

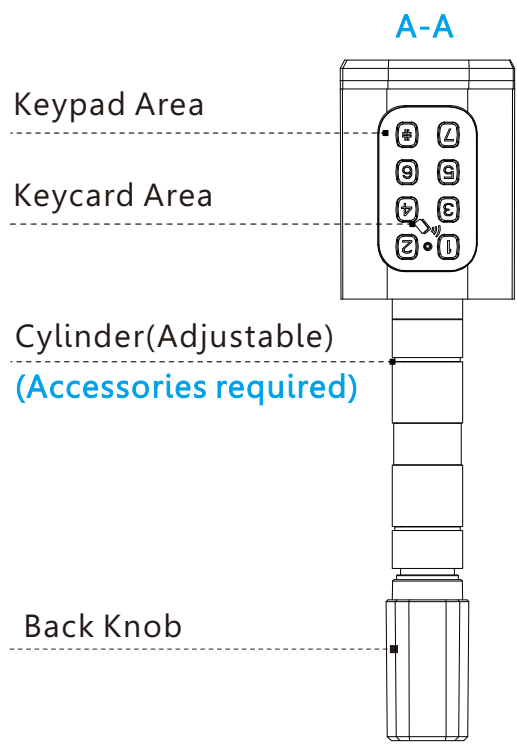

3 Reader View

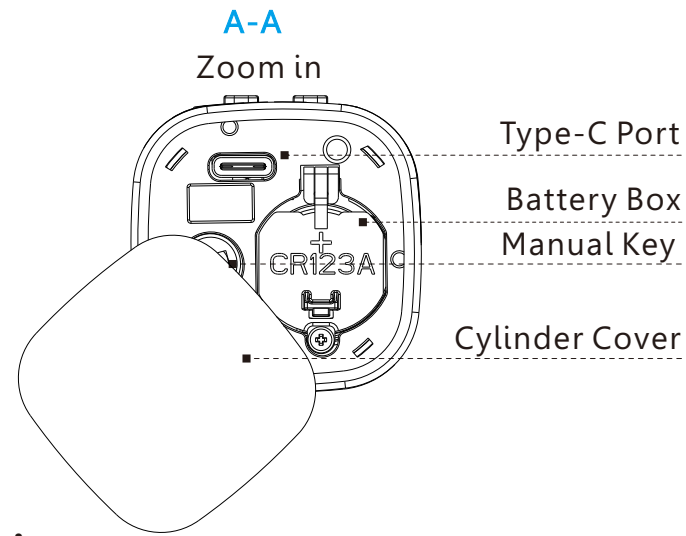

4 Dimension

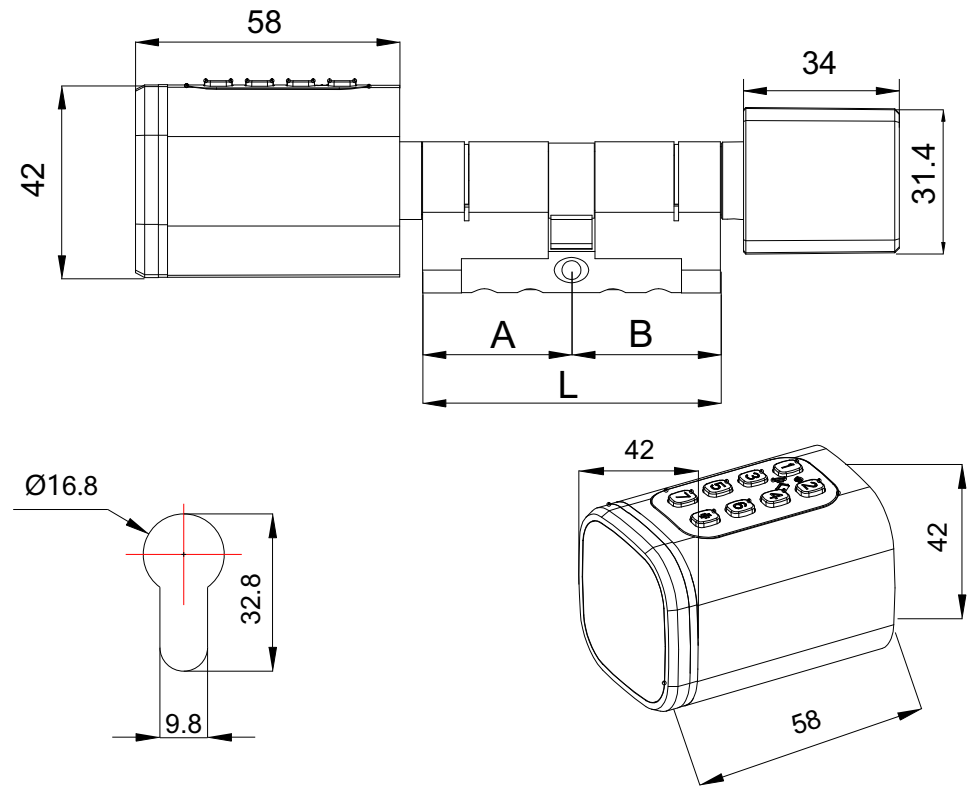

5 INSTALLATION STEPS

5.1 Please use the screw driver to take off the screw on the back knob position, refer the below Pic.1:

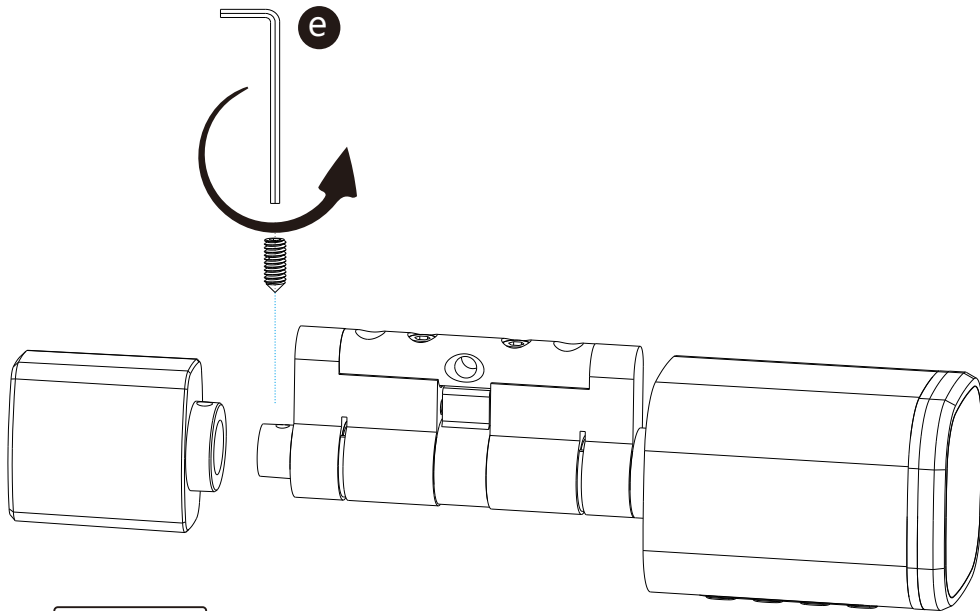

⚠ Attention

Special Notice for Axis Door:

You can use the screw driver to take off the screw on the back knob position and adjust the tail size accordingly, refer the below:

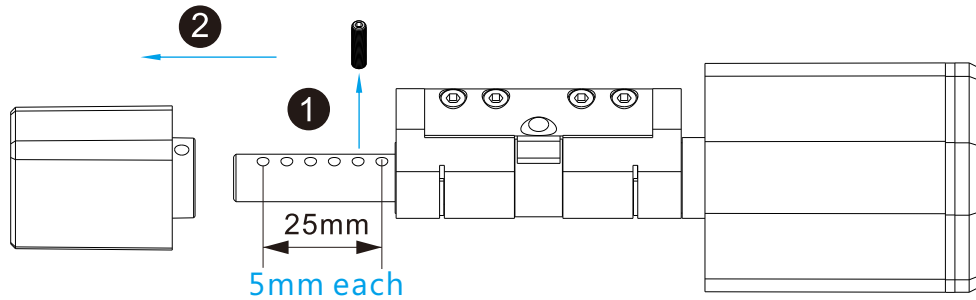

Pic.1

5.2 Please insert the cylinder to the existed lock and fix the cylinder with the long screw as picture 2.

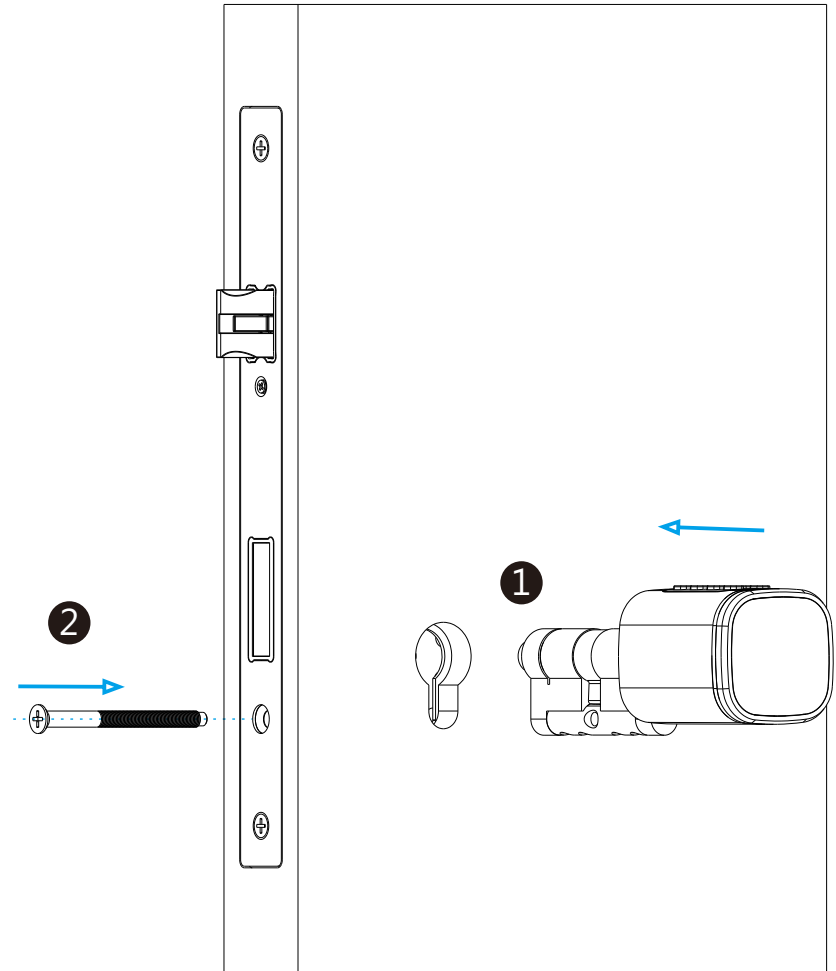

Pic.2

5.3 Please use the screw driver to fasten the screw on the back knob position, refer the below picture 3:

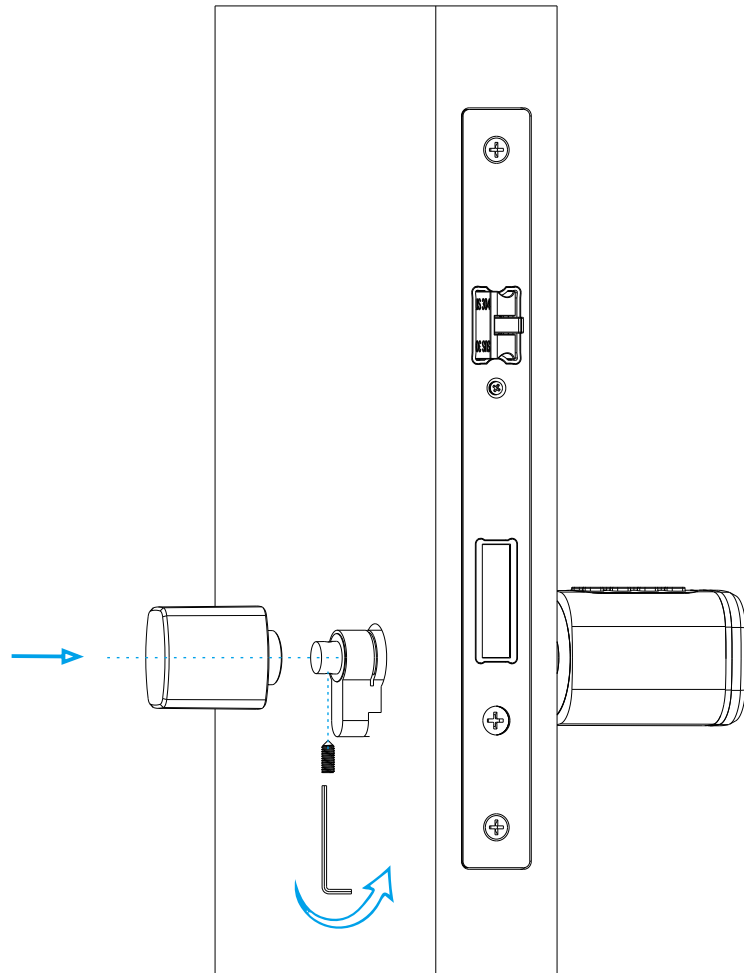

Pic.3

5.4 Please take off the reader cover with the magnet or sucker (included in our accessories bag), assemble 1xCR123A alkaline battery, refer the below picture 4:

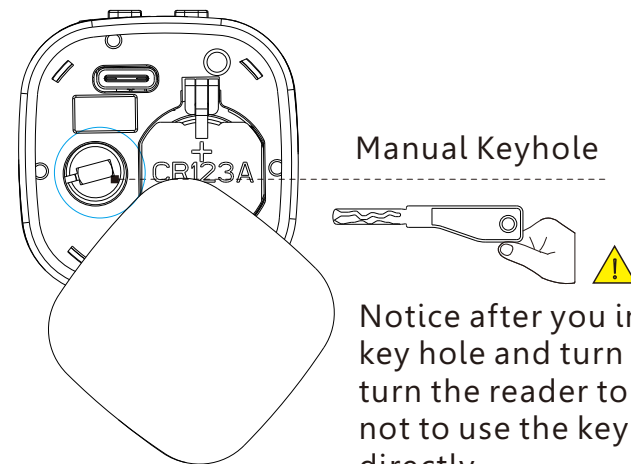
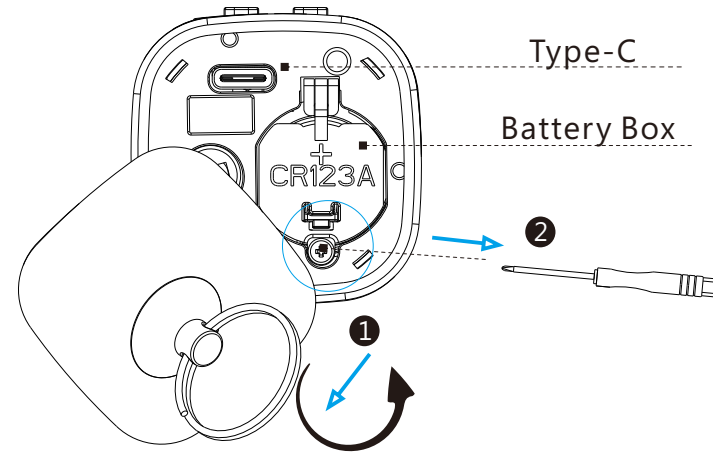

Notice after you insert the key into the key hole and turn clockwise, you shall turn the reader to unlock the door but not to use the key to unlock the door directly.

Pic.4

5.5 Please test with your default password 123456 and end with "# " under the factory state, refer the below picture 5:

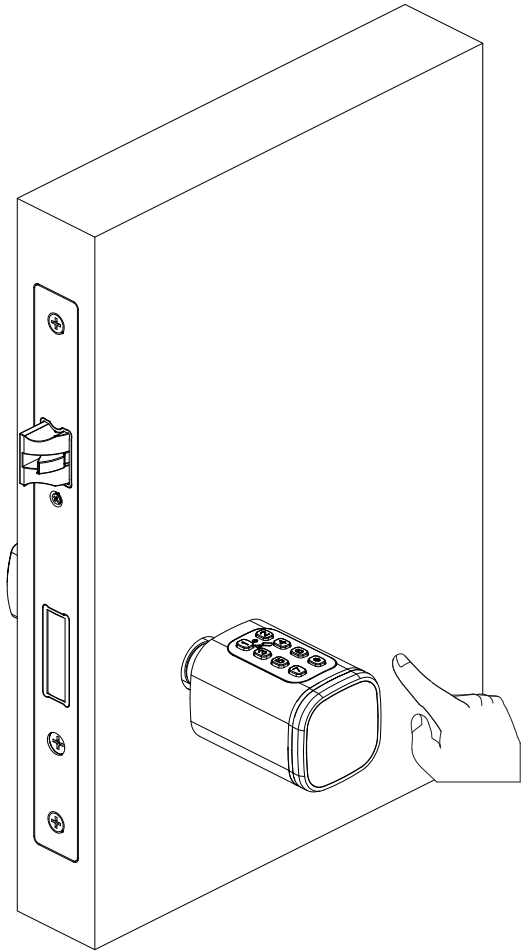

Pic.5

5.6 Please test the lock with key card after you configure the lock with TTLOCK APP(Refer the Part 6).

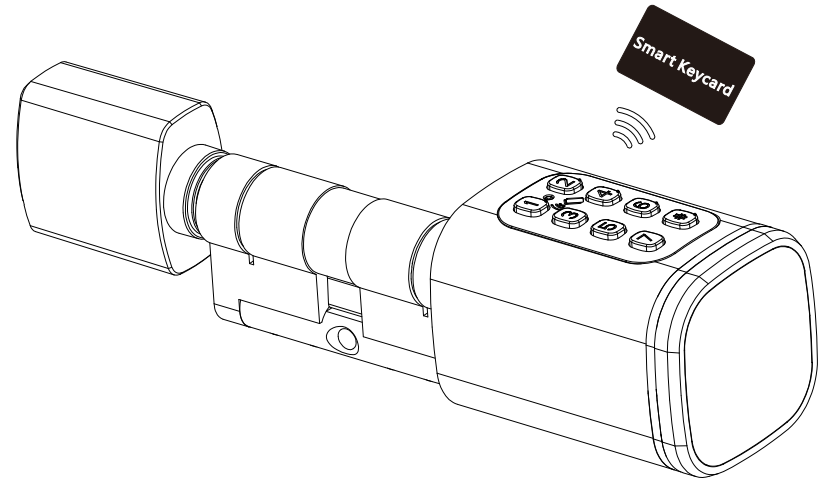

⚠ Attention

Notice the keycard or passcode can only be enrolled by the TTLOCK APP, so it is important to install this app in your mobile before start daily use.

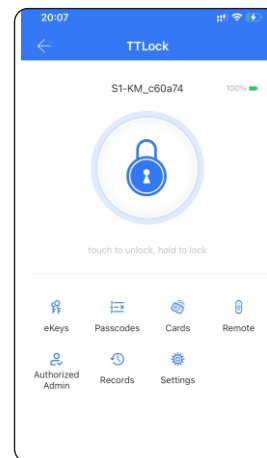

6 TTLOCK APP Settings

Please download the TTLOCK on Apple store or Google play. also you can scan the QR code below to download the APP directly.



6.1 Please register one account with your E-mail or mobile number.

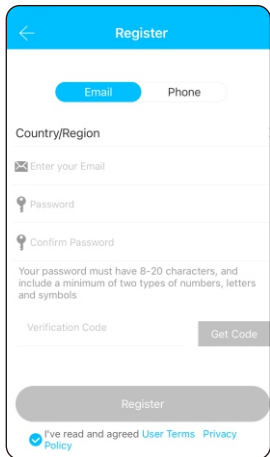

6.1.1 Sign up and Register with mobile or Email

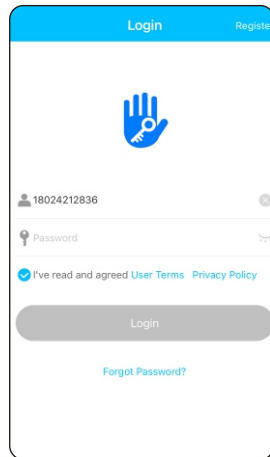

6.1.2 Enter mobile or mail Login with right password

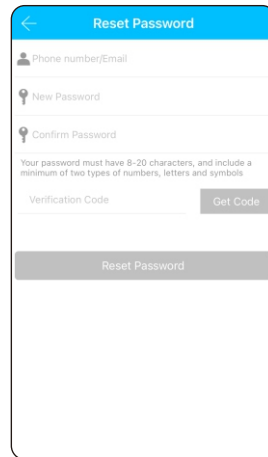

6.1.3 You can reset your password

6.2 Configure the Lock

Please run the TTLOCK APP and click "Add LOCK" on the left side of system setting and follow the steps to configure the lock with APP:

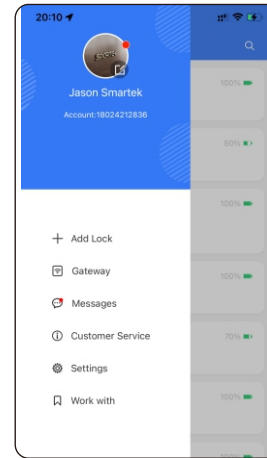

Step 1
Add Lock

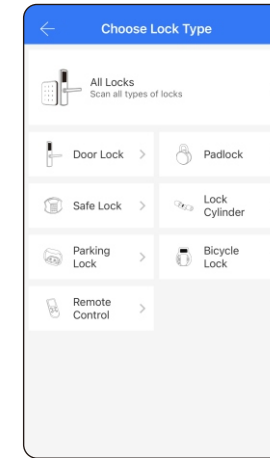

Step 2
Click "All Locks"

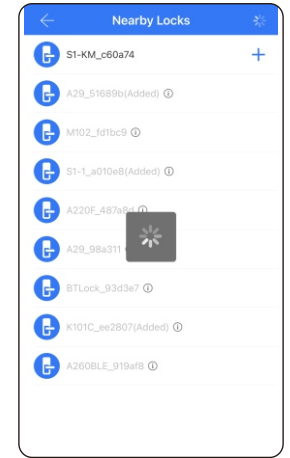

Step 3
Press+
Choose First Lock



Step 4
Add Lock Successfully
Rename the lock

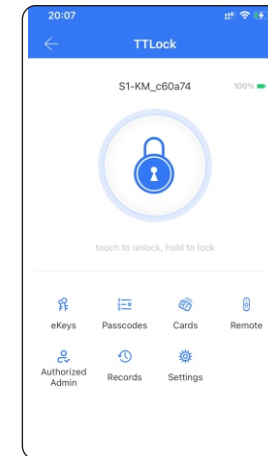

Step 5
Done

6.3 Function Description

Under lock settings, you can see the features for the smart locks, such as eKeys /IC card/Passcode/Remote Unlock unlock records and settings etc.

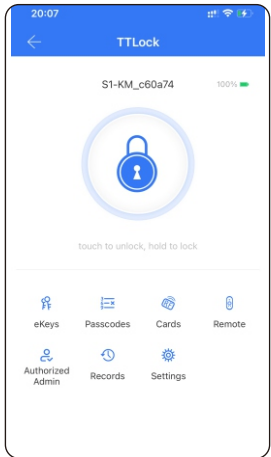

There are many special features under the TTLOCK APP settings. you can make the setting according to your daily requirement.

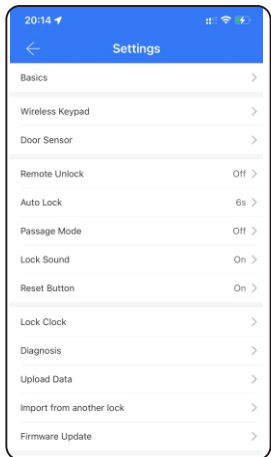

6.4 Enroll User Passcode

Under the lock setting, you can click the passcodes and generate different type passcode. There is permanent/timed and recurring passcodes for different condition.

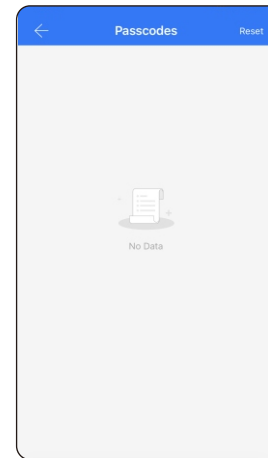

Step 1
Add Passcodes

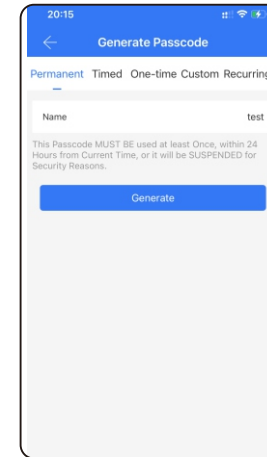

Step 2
Choose Permanent Type
Click Generate

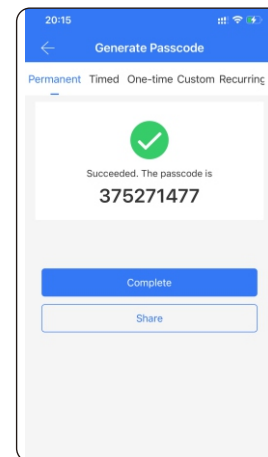

Step 3
Complete or share the passcode
via mail or message

6.5 Enroll User Card

Under the lock setting, you can click the option "Cards" and enroll the IC card. There is permanent /timed and recurring card under for different condition.



Step 1
Add Card

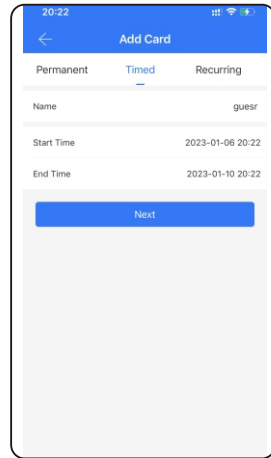

Step 2
Choose Timed Type

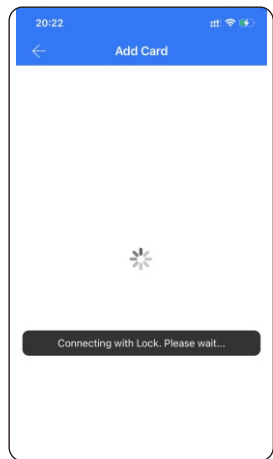

Step 3
Touch IC Card to
the lock induction
area

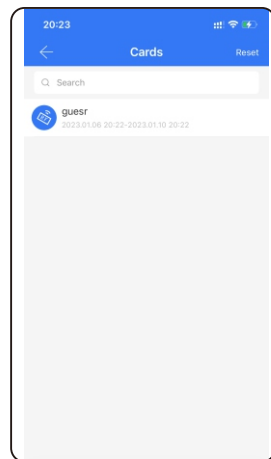

Step 4
Done

6.6 Enroll eKeys

Under the lock setting, you can click the option "eKeys" and enroll the eKeys for other users. There is permanent /timed and recurring eKeys for different condition.

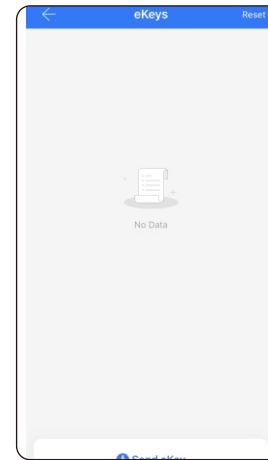

Step 1
Send eKey

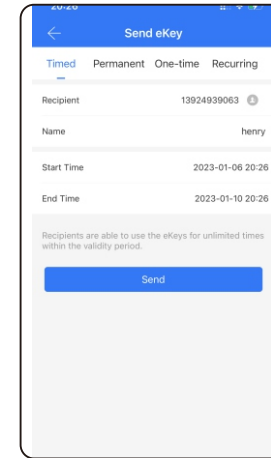

Step 2
Choose Timed Type

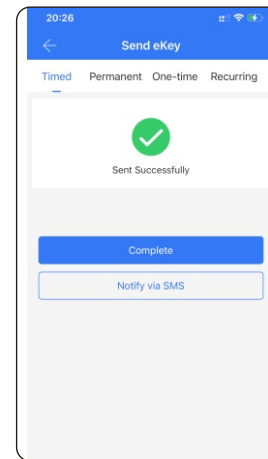

Step 3
Complete, you can share
with SMS to recipient

6.7 Passage Mode

Under the lock setting, you can tick "Passage Mode", under this setting the lock will be in always open state, you can disable the passage mode in the APP too.

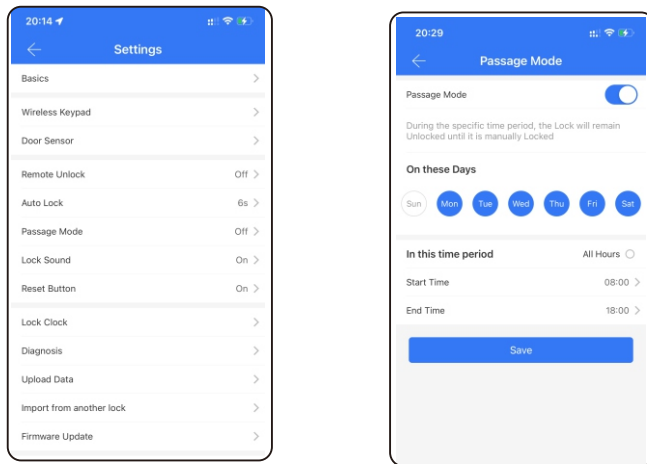

7. Reset the Lock

Under the lock setting, you can click the "Delete" button and enter the admin password to reset the lock and the lock will be set to factory state, you can use default passcode 123456# to unlock the lock.

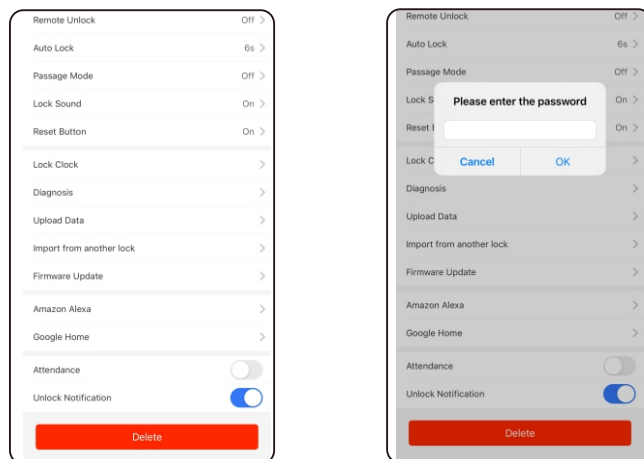

8. Remote Unlock Function (with Gateway)

The Wi-Fi gateway is a must to enable the remote unlock function, please refer the parameters below:

Model: **G2**
 Dimension: 70x70x26mm
 Network: Wi-Fi 2.4G
 IEEE Standard: 802.11b/g/n
 Power Interface: Type C USB
 Power Input: DC5v/500mA

Light Status

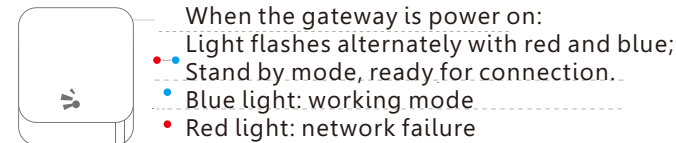

8.1 Pair the Gateway with APP

1. Activate the App on mobile
2. Press the button "≡"
3. Select the [Gateway]
4. Select [G2]
5. Plug the gateway and power on it, when the light flashes alternately with red and blue
6. Press the "+"
7. Add Gateway
8. Select WiFi and enter password
9. Finish pairing gateway

⚠ Notice: If times out, please power on the gateway and try it again.

8.2 Remote Unlock

Under the lock setting, you shall first turn on the remote unlock function as the below photo. then you can click the unlock sign near the round circle, there is one tip for remote unlock, you can click it and unlock the door remotely.

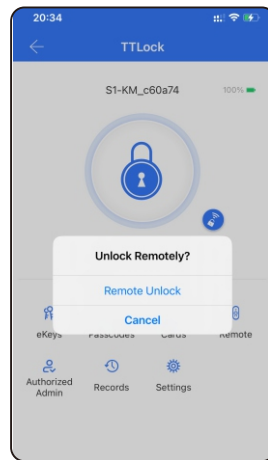
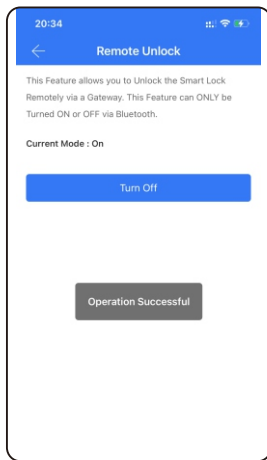

9. Sales and Service Terms

- Please read the manual carefully before use!
- Limited 1-year Electronic Warranty Limited Lifetime Mechanical and Finish Warranty
- This product comes with a 1-year Limited Warranty on Electronic Parts and a Limited lifetime. Mechanical and Finish Warranty against defects in materials and workmanship under normal use to the original residential user. Proof of purchase and ownership is required for the warranty to be in effect.
- Any error or question in our manual or sales term, please feel free to contact with us.
- For any wrong operation or installation to the user, we do not responsible for the duty.
- For the damage caused by anthropic factor or inevitable reason, we do not pay for the loss or maintain for free, please check our after sale service terms.
- Please do not take apart the lock if you are not technician, if necessary, please make the operations under the guide of technician.
- Notice: there maybe a little difference for product pictures with real product, please subject to our real products.